

Minutes EBG meeting	 European forum for energy Business Information eXchange
December 12 th , 2022	EBG (ebIX® Business Group)

Date: Tuesday and Wednesday December 6th and 7th, 2022

Time: 09:00 –16:00 and 09:00 – 15:00

Place: E.ON offices in Hamburg

Present: Jan, Svenska kraftnät (via GoToMeeting)
 Joachim, Westnetz
 Gerrit, EDSN
 Kees, TenneT (via GoToMeeting)
 Ove, Edisys

Appendix A: EBG comments to the Harmonised Electricity Market Role Model (HEMRM)

Appendix B: EBG project and survey list

Appendix C: Mapping from ebIX® class diagrams for Validated measured data for continuous metered AP to CIM

Attachments: None

1 Approval of agenda

The agenda was approved with the following additions:

- Flexibility roles from prequalification IG from ENTSO-E/CIM WG, see item 11.1 under AOB.
- Datahubs, see item 11.2 under AOB.

2 Approval of minutes from previous meeting

The minutes from previous meeting were approved.

3 NMEG 2020/1 - addition of PSRType or similar to AP administrative characteristics and possible rename of the attribute name.

Ref. discussion at EBG meeting October 10th, 2022. Jan and Ove had brought up the topic during a NMEG meeting November 22nd and 23rd.

Conclusion from EBG October 10th:

- Jan and Ove will bring the topic back to NMEG, i.e. try to find a better understanding and name for the attribute and a better justification for why and were to add the attribute (the attribute is used both in aggregated time series and as master data in AP characteristics).

From NMEG discussion November 23rd:

- What NMEG is looking for is not really a PSRType, which is Power System Resource Type, i.e., something physical.
- However, the ENTSO-E PSRType, which uses the ENTSO-E Asset Type Code, contains more than "Resource Types", such as fuel types.

Conclusion from NMEG November 23rd:

- Jan and Ove will inform EBG that the PSRType is the pragmatically correct choice. I.e. we propose adding a “Business Type Detail” or “Aggregation criteria” attribute in the ebIX® BRS model. This attribute can be mapped to PSRType in CIM that is of type ASSET Type.

After a short discussion it was agreed to go for the term “Consumption detail”.

Based on the discussions, the following changes were agreed for the BRS for Measure for imbalance settlement:

- Addition of Consumption detail to the Series characteristics class in the Validated measured data for imbalance settlement document.
- Removal of the Energy Label class and moving of the Fuel and Technology attributes to the Series characteristics class in the Validated measured data for imbalance settlement document.

Changes to BRS for AP characteristics:

- Rename of the class “Reconciliation information” to “Energy volume information” in the Accounting Point characteristics document.
- Addition of the attribute “Consumption detail” to the “Energy volume information” class in the Accounting Point characteristics document.
- Addition of Metered Data Administrator ID and Metering Point Administrator ID in the Accounting Point characteristics document.
- Addition of Accounting Point level and Grid Connection ID to the Accounting Point characteristics document.

The BRS for Measure for imbalance settlement and the BRS for AP characteristics were updated during the meeting.

Action:

- Ove will go through the other Measure BRSs to see if we should add Consumption detail and/or move Fuel and Technology.
- Ove will go through the other Structure BRSs to see if we should rename the class “Reconciliation information” to “Energy volume information” and/or add attribute “Consumption detail” to “Energy volume information” class.
- Ove will send the BRS for Measure for imbalance settlement and the BRS for AP characteristics to EBG and Forum for circulation for comments for four weeks before publication.

4 Preparation of “Alignment of master data for areas project”

The ebIX® Forum decided at the ebIX® Forum meeting in November to start the common European energy project for alignment of master data for areas, even if we still are missing member(s) from the EU DSO Entity.

Currently we have the following confirmed participants in the common European energy market “Alignment of master data for areas” project:

Name	Company	Representing	Response
Bartosz Kwiatkowski	PSE	ebIX®	
Douglas Hill	ENTSOG	ENTSOG (observer)	Thursdays fits best.
Gerrit Fokkema (Convenor)	EDSN	ebIX®	
Jan Owe	Svenska kraftnät	ebIX® and ENTSO-E (observer)	
Joachim Schlegel	Westnetz	ebIX®	

Jon-Egil Nordvik	Statnett	ENTSO-E/CIM EG	
Kees Sparreboom	TenneT	ebIX® or ENTSO-E	
Ove Nesvik (Secretary)	Edisys	ebIX®	
?	?	EU DSO Entity	

The following invitation was sent to the members during the meeting:

We suggest running the meeting on every second Tuesday mornings 10:00 to 12:00, starting with a kick off on Tuesday January 17th.

An alternative could be every second Thursday morning, also from 10:00 to 12:00, starting with a kick off meeting Thursday January 26th.

Please let us know as soon as possible, and **latest by the end of this week**, if any of these time slot fits your calendar.

We suggest the following agenda for the kick off meeting:

1. Welcome and brief introduction of project members
2. Review of project plan
3. Agree the way of working and meeting schedule, including discussions if the meeting shall be on-line meetings and/or physical meetings
4. Start on the Business Requirements (BRS) for alignment of MGA characteristics.

A reminder for coming up with participants was sent to Paul, Georg and Vlatka in the EU DSO Entity.

Action:

- Ove will prepare a first BRS skeleton

5 Sub APs and production-/consumption APs

The survey was reviewed and thereafter it was discussed how to structure several APs in our BRSs.

- Jan informed of the Danish principles:

In Denmark there is a concept of "parent/child" accounting points. It is at the parent you switch supplier, but the metering is (also) done at the level of the children - but that energy is not part of the imbalance settlement. Here follows a description of this: According to the settlement of wholesale services, ..., the grid operator may link other metering points to consumption and production metering points in a parent/child structure. Child metering points (also called other metering points) will not be included in the balance settlement but will be included in the wholesale settlement between the grid operator and the balance supplier for the consumption/production metering point.

Further: A child metering point is established to handle the situation where the wholesale settlement between the grid operator and the balance supplier cannot be based directly on the energy amounts registered for the consumption or production metering point. ...

- The following additions were made to the BRS for AP characteristics:
 - Addition of Metered Data Administrator ID and Metering Point Administrator ID to the Accounting Point characteristics document.
 - Addition of Accounting Point level and Grid Connection ID to the Accounting Point characteristics document.
- An introduction chapter was added to the BRS for AP characteristics, explaining the Grid connection, main AP and sub-AP:

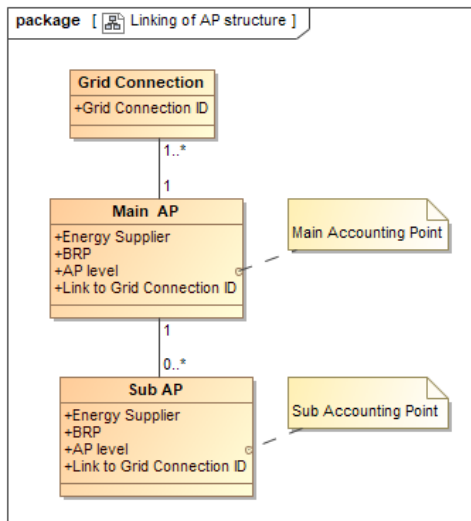

Action:

- Ove will go through the other Structure BRs to see if we should add Metered Data Administrator ID and/or Metering Point Administrator ID or add Accounting Point level and Grid Connection ID to the root class.

6 Review of HEMRM definitions

The last part of the meeting was used to review the definitions HEMRM definitions, see Appendix A.

7 What attributes to send in a confirmation

The item was postponed.

8 Review of CIM definitions for classes and attributes based on mapping from ebIX® class diagrams for Validated measured data for continuous metered AP to CIM

The item was postponed.

9 Review of ebIX domain model (low priority item)

The item was postponed.

10 Meeting schedule

GoToMeetings:

- Every Monday from January 9th until (including) July 3rd, 2023, except for holydays.

Physical meeting:

- Tuesday April 25th and Wednesday April 26th at Svenska kraftnät's offices in Sundbyberg (Stockholm).

11 AOB

11.1 Flexibility roles from prequalification IG from ENTSO-E/CIM WG

ENTSO-E has started to work on the implementation guide for prequalification. After having a look at the BRS from eBIX[®] and the Acer framework guideline on demand response, they have identified the following use cases and roles (See below). Hence, ENTSO-E has asked for HG feedback on the flexibility related roles in the UC diagram below and asked the HG to discuss their inclusion in the HEMRM.

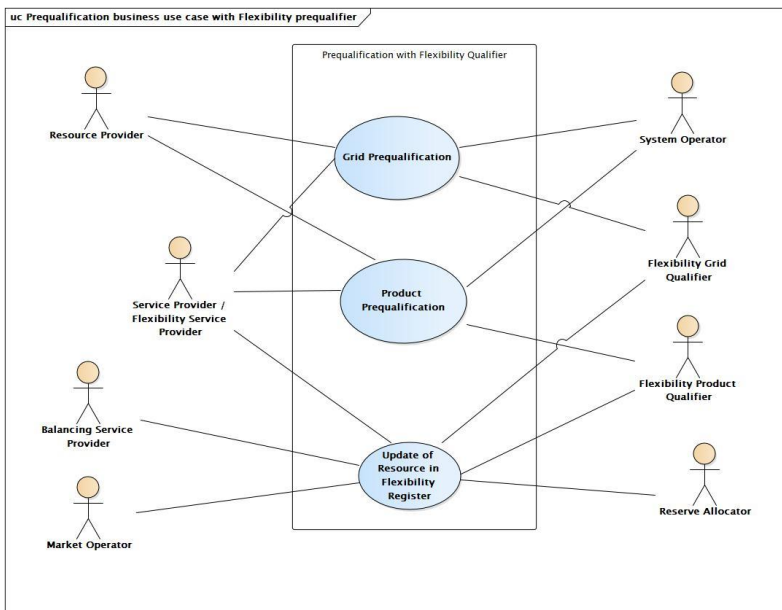

The UseCases were reviewed with the following comments:

- The UseCases should be named in imperative tense, e.g. "Get product pre-qualification" or "Get grid pre-qualification".
- The System Operator, Resource Provider (and "Service Provider (who is he?)") doesn't participate in the pre-qualification itself. They are informed via the Flexibility Register Administrator.
- Only the FSP, Product Qualifier and Grid Qualifier can update the flexibility register.
- We don't understand what the Reserve Allocator does.
- The BSP should be a specialisation of the FSP.
- The MO and Reserve Allocator are no part of the UC for update of the flexibility register. However, they can be notified or request information.

Kees will bring the comments back to ENTSO-E and Jan, Kees and Ove will show the comments to the Harmonisation Group (HG).

11.2 Datahubs

Questions for Data Hub discussion from Germany.

The Metering Point administration is in general performed in the datahub, meaning the processes are executed in the datahub and related data (like master data and process data) are stored in the datahub.

1. In the last survey, we did not have a distinction between which processes are executed in the Data Hub and which processes are merely supported by the Data Hub. Sylvia understood that some processes, e.g. change of supplier, are executed in the Data Hub and also the data needed for the process must be stored in the Data Hub (~ Client-Server application) .

Answer:

- In the Nordic countries (Denmark, Finland and Norway) the Netherlands, Poland and Belgium, most market processes (change of supplier, exchange of master data, measurements, imbalance settlement etc.) are run in the datahub and the related data are stored in the datahub. The exception is billing which only is handled in the Danish datahub.

However, there may be data, such as meter characteristics, which is not used in the market processes but still needed by the actors, i.e. only stored by the owner of the data, but exchanged between the parties via the hub.

2. Are there any processes that are executed in the Data Hub where the required data are not stored in the Data Hub? The required data are requested from the systems of the market partners and only temporarily transferred to the Data Hub for process execution. These data are not stored in the Data Hub. (If necessary, only for verification purposes)

Answer:

- No one could think of any processes where only the processing is done in the datahub. I.e. all known datahubs store the relevant data for the processes. However, there are national rules (GDPR) limiting the period the data can be stored.

3. In general: Where are the master and transaction data located? (In the systems of the market partners or in the Data Hub?) Are there differences within the master data/transaction data?

Answer:

- The authoritative source for master data and transaction data is the datahub, however all partners in the chain (the datahub, Energy Supplier, grid company etc.) are responsible for storing/logging of their own transaction data and master data.

4. How is the connection from Data Hub to the backend systems of the market partners established? (Per Web Service?)

Answer:

- In Norway the communication is based on web services (not AS4).
- EDSN (the Netherlands) has a lot of web services (using SOAP), rest API and AS4.

5. Is there a “conversation” between the systems of the market partners with the Data Hub? (Web Service?) Which protocols are in use? (SOAP, REST, other?)

Answer:

- See above.

6. Which safety concept is applied? (AS4, VPN, SSL...)?

Answer:

- In Netherlands, for all communication lines the TLS 1.3 security protocol is being implemented. For the other levels in the communication stack SSL is used. For instance AS4 uses TLS and SSL.

Appendix A EBG comments to the Harmonised Electricity Market Role Model (HEMRM)

A.1 Roles

ROLES			
TYPE	ROLE NAME	DESCRIPTION	EBG COMMENTS
Role	Balance Responsible Party	<p>A Balance Responsible Party is responsible for its imbalances, meaning the difference between the energy volume physically injected to or withdrawn from the system and the final nominated energy volume, including any imbalance adjustment within a given imbalance settlement period.</p> <p>Note: Based on Electricity Balancing - Art.2 Definitions.</p> <p>Additional information: Responsibility for imbalances (Balance responsibility) requires a contract proving financial security with the Imbalance Settlement Responsible of the Scheduling Area entitling the party to operate in the market.</p>	<p>20221017:</p> <ul style="list-style-type: none"> Under discussion in the HG, hence we will await an EBG review until finalised there. <p>Hint: “the system” will need a proper definition</p>
Role	Balancing Service Provider	<p>A party with reserve-providing units or reserve-providing groups able to provide balancing services to one or more LFC Operators.</p> <p>Additional information: Based on Electricity Balancing - Art.2 Definitions.</p>	<p>20220620 - updated 20221031:</p> <ul style="list-style-type: none"> Comments already forwarded to HG. <ol style="list-style-type: none"> Replace the Balancing Service Provider with the Flexibility Service Provider (FSP) and make the BSP a specialisation of the FSP, with the following definition: A Flexibility Service Provider is a party that offers flexibility services to the energy and capacity market based on acquired (aggregated) capabilities¹ Change the definition of the BSP to: A party that offers with reserve-providing units or reserve-providing groups able to provide energy balancing services to one

¹ In this document, the role Flexibility Service Provider corresponds to the *Independent aggregator*, a market participant engaged in aggregation who is not affiliated to the customer's according to the Directive (EU) 2019/944.

ROLES			
TYPE	ROLE NAME	DESCRIPTION	EBG COMMENTS
			or more LFC Operators the energy or capacity market.
Role	Billing Agent	The party responsible for invoicing a concerned party.	<p>20221017:</p> <ul style="list-style-type: none"> Rephrase to: The A party servicing the responsible for invoicing for one or more a concerned party/parties.
Role	Capacity Trader	<p>A party that has a contract to participate in the Capacity Market to acquire capacity through a Transmission Capacity Allocator.</p> <p>Note: The capacity may be acquired on behalf of an Interconnection Trade Responsible or for sale on secondary capacity markets.</p>	<p>20221017:</p> <ul style="list-style-type: none"> Contract with whom?
Role	Consumer	<p>A party that consumes energy.</p> <p>Additional information: This is a Type of Party Connected to the Grid.</p>	<p>20221017:</p> <ul style="list-style-type: none"> Rephrase to: A party that consumes energy taken from the grid. In addition we would like to add a general definition of the term “grid” as part of the introduction to the HEMRM, e.g.: A grid is a physical constitution (of connected galvanic cables (electricity) or pipes (gas)) to distribute energy to or from other grids and/or Parties Connected to the Grid. Alternatively use “the system” instead of “the grid”, but then the system needs a proper definition too.
Role	Consumption Responsible Party	A Consumption Responsible Party is responsible for its imbalances, meaning the difference between the energy volume physically withdrawn from the system and the final nominated energy volume, including any imbalance	<p>20221017:</p> <ul style="list-style-type: none"> Under discussion in the HG, hence we will await an EBG review until finalised there.

ROLES			
TYPE	ROLE NAME	DESCRIPTION	EBG COMMENTS
		adjustment within a given imbalance settlement period. Additional information: This is a type of Balance Responsible Party.	
Role	Consent Administrator	A party responsible for administrating a register of consents for a domain. The Consent Administrator makes this information available on request for entitled parties in the sector.	20221017: <ul style="list-style-type: none"> Rephrase to: A party responsible for keeping a register of consents, for a purpose and a specified period for a certain set of data for an Accounting Point or a Resource at an Accounting Point. The Consent Administrator makes this information available on request from Data Providers in the sector.
Role	Coordinated Capacity Calculator	Coordinated Capacity Calculator is the entity or entities with the task of calculating transmission capacity, at regional level or above. Source: Commission Regulation (EU) 2015/1222 (CACM) .	20221017: <ul style="list-style-type: none"> Rephrase to: Coordinated Capacity Calculator is the A party entity or entities with the task of calculating transmission capacity, at regional level or above. Source: Commission Regulation (EU) 2015/1222 (CACM). And add a definition of transmission capacity in the introduction of the HEMRM.
Role	Coordination Centre Operator	A party responsible for the coordination of its Coordination Centre Zone in respect of scheduling, load frequency control, time deviation and compensation of unintentional deviation.	20221017: <ul style="list-style-type: none"> Outside of ebIX® scope.
Role	Data Provider	A party that has a mandate to provide information to other parties in the energy market. Note: For example, due to Article 2 of the European Commission Regulation 543/2013 of the 14th of June 2013 , a	20221017: <ul style="list-style-type: none"> Mandated by whom? Is it better to rephrase to: A party that has a mandate to provide provides a certain set of

ROLES			
TYPE	ROLE NAME	DESCRIPTION	EBG COMMENTS
		data provider may be a Transmission System Operator or a third party agreed by a TSO.	information data to other parties in the energy market.
Role	Energy Service Company	A party offering energy-related services to the Party Connected to Grid, but not directly active in the energy value chain or the physical infrastructure itself. Additional info: The Energy Service Company (ESCO) may for example provide insight services as well as energy management services.	20221024: • Rephrase to: A party offering energy-related services, not part of the regulated services , to the Party Connected to Grid, but not directly active in the value chain or the physical infrastructure itself. Additional info²: The Energy Service Company (ESCO) may for example provide insight services as well as energy management services.
Role	Energy Supplier	Current definition in HEMRM 2022-01: An Energy Supplier supplies electricity to or takes electricity from a Party Connected to the Grid at an Accounting Point. Additional information: An Accounting Point can only have one Energy Supplier. When additional suppliers are needed the Energy Supplier delivers/takes the difference between established (e.g. measured or calculated) production/consumption and the (accumulated) contracts with other suppliers. New HG agreed definition for HEMRM 2023-01: An Energy Supplier supplies delivers electricity energy to or takes	20220620: • Comments already forwarded to HG: ○ The second paragraph of “Additional information” must be rephrased or skipped. ○ We suggest adding a paragraph explaining that if more than one Energy Supplier is needed, this may be solved by using “Sub-Accounting Points”, treated as “normal Accounting Points”. 20221207: • Should the Energy Supplier deliver or take out to/from the grid instead of to/from the Party Connected to the Grid? (Makes it easier for sub-accounting points), i.e.: <i>An Energy Supplier delivers energy to or takes energy via the grid from a Party Connected to the Grid at an Accounting Point.</i>

² This is just examples, hence shouldn't be there.

ROLES			
TYPE	ROLE NAME	DESCRIPTION	EBG COMMENTS
		<p>electricity energy from a Party Connected to the Grid at an Accounting Point.</p> <p>Additional information: An Accounting Point can only have one Energy Supplier. When additional suppliers are needed the Energy Supplier delivers/takes the difference between established (e.g. measured or calculated) production/consumption and the (accumulated) contracts with other suppliers.</p>	
Role	Energy Trader	A party that is selling or buying energy.	<p>20221031: This makes all Customers also Energy Traders. Maybe link it to wholesale?</p> <ul style="list-style-type: none"> • Rephrase to: A party that is selling or buying energy in the wholesale energy market, i.e. selling or buying in large quantities with the intent to be sold again to make a profit.
Role	Grid Access Provider	A party responsible for providing access to the grid through an Accounting Point for energy consumption or production by the Party Connected to the Grid. The Grid Access Provider is also responsible for creating and terminating Accounting Points.	<p>20221024 - updated 20221031:</p> <ul style="list-style-type: none"> • Rephrase to: <i>A party responsible for providing a Party Connected to the Grid the ability to take energy from or feed energy into the grid through an Accounting Point.</i> <p>Additional information: <i>The Grid Access Provider is also responsible for creating and terminating Accounting Points.</i></p>
Role	Imbalance Settlement Responsible	<p>A party that is responsible for settlement of the difference between the contracted quantities with physical delivery and the established quantities of energy products for the Balance Responsible Parties in a Scheduling Area.</p> <p>Note:</p>	<p>20221031:</p> <ul style="list-style-type: none"> • Rephrase to: <i>A party responsible for determination of the difference between the nominated energy quantities and the delivered energy quantities of energy products per Balance Responsible Party in a Scheduling Area.</i>

ROLES			
TYPE	ROLE NAME	DESCRIPTION	EBG COMMENTS
		The Imbalance Settlement Responsible may delegate the invoicing responsibility to a more generic role such as a Billing Agent.	Additional information: <i>The Imbalance Settlement Responsible may delegate the invoicing responsibility to a more generic role such as a Billing Agent.</i>
Role	Interconnection Trade Responsible	Is a Balance Responsible Party or depends on one. He is recognised by the Nomination Validator for the nomination of already allocated capacity. Additional information: This is a type of Balance Responsible Party.	20221207: • This is not a definition (it contradicts itself and doesn't explain what the role does)
Role	LFC Operator	Responsible for the load frequency control for its LFC Area or LFC Block. Additional information: This role is typically performed by a TSO.	20221207: • Rephrase to: <i>A party responsible for the frequency control of the load of a LFC Area or a LFC Block</i> Additional information: <i>This role is typically performed by a TSO.</i>
Role	Market Information Aggregator	A party that provides market related information that has been compiled from the figures supplied by different actors in the market. This information may also be published or distributed for general use. Note: The Market Information Aggregator may receive information from any market participant that is relevant for publication or distribution.	20221207: • Rephrase to: <i>A party publishing market related information, compiled from information supplied by different actors in the market.</i> Additional information: <i>The Market Information Aggregator may receive information from any market participant that is relevant for publication or distribution.</i>
Role	Market Operator	A party that provides a service whereby the offers to sell electricity are matched with bids to buy electricity. Additional Information: The definition above is based on Regulation on the internal market for electricity (EU) 2019/943 : A more detailed description:	20221207: • Rename electricity with energy.

Commented [GF1]: Maybe:
A party that providing services for matching offers to sell electricity with bids to buy energy

ROLES			
TYPE	ROLE NAME	DESCRIPTION	EBG COMMENTS
		<p>A party that provides a service of collecting offers to sell and bids to buy electricity, and matching these offers and bids in order to determine a market price at the clearing point. This activity can be conducted in the forward, days-ahead and/or intraday timeframes, and can be combined with transmission capacity allocation in the context of market coupling.</p> <p>This is usually an energy/power exchange or platform.</p>	
Role	Merit Order List Responsible	Responsible for the management of the available tenders for all Acquiring LFC Operators to establish the order of the reserve capacity that can be activated.	<p>20221207:</p> <ul style="list-style-type: none"> • What is meant by “...all Acquiring LFC Operators....”? • Then rephrase to the format: A party responsible...
Role	Meter Administrator	A party responsible for keeping a database of meters.	<p>20221207:</p> <ul style="list-style-type: none"> • Rephrase to: <i>A party responsible for administrating Meter characteristics and making these Meter characteristics available for entitled market parties.</i>
Role	Meter Operator	A party responsible for installing, maintaining, testing, certifying and decommissioning physical meters.	
Role	Metered Data Administrator	A party responsible for storing and distributing validated measured data.	<p>20221207:</p> <ul style="list-style-type: none"> • Rephrase to: <i>A party responsible for storing validated measured data and making these validated measured data available for entitled market parties.</i> <p>Additional information: <i>The Metered Data Administrator is responsible for the history of measured data for a Metering Point.</i></p>
Role	Metered Data Aggregator	A party responsible for the establishment and qualification of	<p>20221207:</p> <ul style="list-style-type: none"> • Rephrase to:

ROLES			
TYPE	ROLE NAME	DESCRIPTION	EBG COMMENTS
		measured data from the Metered Data Responsible. This data is aggregated according to a defined set of market rules.	<i>A party responsible for aggregating validated measured data for an area according to a defined set of market rules and making these available for entitled market parties.</i>
Role	Metered Data Collector	A party responsible for meter reading and quality control of the reading.	20221207: <ul style="list-style-type: none"> Rephrase to: <i>A party responsible for reading a meter, including quality control of the reading.</i>
Role	Metered Data Responsible	A party responsible for the establishment and validation of measured data based on the collected data received from the Metered Data Collector. The party is responsible for the history of metered data for a Metering Point.	20221207: <ul style="list-style-type: none"> Rephrase to: <i>A party responsible for the validation of measured data, either received from the Metered Data Collector or estimated.</i> Additional information: <i>The Metered Data Responsible is responsible for determining the volume of the consumed and/or produced energy at a Metering Point.</i>
Role	Metering Point Administrator	A party responsible for administrating and making available the Metering Point characteristics, including registering the parties linked to the Metering Point.	20221207: <ul style="list-style-type: none"> Rephrase to: <i>A party responsible for administrating Metering Point characteristics and making these characteristics available for entitled market parties.</i> Additional information: <i>The Metering Point Administrator is responsible for registering the parties linked to a Metering Point.</i>
Role	Model Merging Agent	A party responsible for establishing a merged model and ensuring its completeness, consistency and quality. Additional information: The definition is based on CGM BP IG.	20221207: <ul style="list-style-type: none"> Rename “model” to “grid model” both in the name and definition. This makes it easier for non CGM experts to know what the role does.
Role	Modelling Authority	A party accountable for the sourcing, consistency and quality of one or more model datasets.	20221207: <ul style="list-style-type: none"> See previous comment.

Commented [GF2]: Shouldn't we also state the the meter reads are send to the entitled market parties

ROLES			
TYPE	ROLE NAME	DESCRIPTION	EBG COMMENTS
Role	Nominated Electricity Market Operator	<p>An entity designated by the competent authority to perform tasks related to single day-ahead or single intraday coupling.</p> <p>Source: Commission Regulation (EU) 2015/1222 (CACM).</p> <p>Additional Information:</p> <p>A NEMO performs MCO (Market Coupling Operator) and CCP (Central Counter Party) functions.</p> <p>A NEMO runs a power exchange related to day-ahead or intraday market.</p> <p>A NEMO is a type of Market Operator.</p>	<p>20221207:</p> <ul style="list-style-type: none"> • Rename “entity” to “party”.
Role	Nomination Validator	<p>Has the responsibility of ensuring that all capacity nominated is within the allowed limits and confirming all valid nominations to all involved parties. He informs the Interconnection Trade Responsible of the maximum nominated capacity allowed. Depending on market rules for a given interconnection the corresponding System Operators may appoint one Nomination Validator.</p>	<p>20221207:</p> <ul style="list-style-type: none"> • Rephrase to: <p><i>A party responsible for ensuring that all capacity nominated for an interconnection is within the allowed limits and confirming all valid nominations to all involved parties. The party informs the Interconnection Trade Responsible of the maximum nominated capacity allowed.</i></p> <p>Additional information:</p> <p><i>Depending on market rules for a given interconnection the corresponding System Operators may appoint one Nomination Validator.</i></p> <ul style="list-style-type: none"> • The interconnection needs to be defined.
Role	Party Administrator	<p>A party responsible for maintaining party characteristics for the energy sector.</p>	<p>20221207:</p> <ul style="list-style-type: none"> • Rephrase to: <p><i>A party responsible for administrating party characteristics and making these party characteristics available for entitled energy market parties.</i></p>
Role	Party Connected to the Grid	<p>A party that contracts for the right to take out or feed in energy at an Accounting Point.</p>	<p>20221207:</p> <ul style="list-style-type: none"> • Rephrase to:

ROLES			
TYPE	ROLE NAME	DESCRIPTION	EBG COMMENTS
			<p><i>A party that contracts for the right to take out from or feed in energy into the grid at an Accounting Point.</i></p> <ul style="list-style-type: none"> • With whom? If the focus is on the contract why not rephrase to “Party Contracted to the Grid?”
Role	Producer	<p>A party that generates electricity.</p> <p>Additional information:</p> <p>This is a type of Party Connected to the Grid.</p> <p>The definition is based on Directive (EU) 2019/944 of the European Parliament and of the Council of 5 June 2019 on common rules for the internal market for electricity and amending Directive 2012/27/EU, Article 2 (Definitions).</p>	
Role	Production Responsible Party	<p>A Production Responsible Party is responsible for its imbalances, meaning the difference between the energy volume physically injected to the system and the final nominated energy volume, including any imbalance adjustment within a given imbalance settlement period.</p> <p>Additional information:</p> <p>This is a type of Balance Responsible Party.</p>	
Role	Reconciliation Accountable	<p>A party that is financially accountable for the reconciled volume of energy products for a profiled Accounting Point.</p>	
Role	Reconciliation Responsible	<p>A party that is responsible for reconciling, within a Metering Grid Area, the volumes used in the imbalance settlement process for profiled Accounting Points and the actual measured quantities.</p> <p>Note:</p>	

Commented [GF3]: Shouldn't we link it to feeding energy into the Grid – similar to Consumer

ROLES			
TYPE	ROLE NAME	DESCRIPTION	EBG COMMENTS
		The Reconciliation Responsible may delegate the invoicing responsibility to a more generic role such as a Billing Agent.	
Role	Reserve Allocator	Informs the market of reserve requirements, receives bids against the requirements and in compliance with the prequalification criteria, determines which bids meet requirements and assigns bids.	
Role	Resource Aggregator	<p>A party that aggregates resources for usage by a service provider for energy market services.</p> <p>Note: In the current version, the only service provider in HRM is the Balancing Service Provider.</p>	<p>20220620:</p> <ul style="list-style-type: none"> • Comments already forwarded to HG: <ul style="list-style-type: none"> ○ We are missing the “bigger picture”, i.e. we should look at all the new roles identified in the flex arena. We question if a Resource Aggregator really is needed, as we see no need for a role for purely aggregation of Resources. It must at least be linked to the Service Provider roles, such as the BSP role. However, it would probably be better to replace the Resource Aggregator with the FSP (Flexibility Service Provider) or one or more Service Providers that also do the aggregation. We think that in the future it will be difficult to differentiate between different kinds of flexibility service providers and that an FSP will offer services in multiple ‘flexibility domains’, as for Congestion, Frequency, etc. <p>20220627:</p> <ul style="list-style-type: none"> • Comments already forwarded to HG: <ul style="list-style-type: none"> a) We support moving of the association to go to the Resource instead of the Accounting Point. b) The text “... to aggregate within ... Resource” sounds strange. We suggest removing the “Additional information”. <p>In general we think the roles and domains needed for energy flexibility</p>

ROLES			
TYPE	ROLE NAME	DESCRIPTION	EBG COMMENTS
			services should be more generic than in the current HEMRM, such as:
Role	Resource Capacity Mechanism Operator	<p>A party responsible to operate the resource capacity mechanism in a member state.</p> <p>Additional information:</p> <p>It can either be the TSO or an independent party. A Resource Capacity Mechanism Operator can contract one or several Resource capacity market units, and a resource capacity market unit can only be contracted by one Resource Capacity Mechanism Operator.</p>	
Role	Resource Provider	<p>A role that manages a resource and provides production/consumption schedules for it, if required.</p>	
Role	Scheduling Agent	<p>The entity or entities with the task of providing schedules.</p> <p>Source: System Operation Guideline, Commission Regulation (EU) 2017/1485.</p> <p>Additional information:</p> <p>A party that is responsible for the schedule information and its exchange on behalf of a Balance Responsible Party.</p>	
Role	Scheduling Area Responsible	<p>A party responsible for the coordination of nominated volumes within a scheduling area.</p> <p>Additional information:</p> <p>This role is typically performed by a TSO.</p>	
Role	System Operator	<p>A party responsible for operating, ensuring the maintenance of and, if necessary, developing the system in a given area and, where applicable, its interconnections with other systems, and for ensuring the long-term ability of the system to meet reasonable demands for the distribution or transmission of electricity.</p> <p>Additional information:</p>	

ROLES			
TYPE	ROLE NAME	DESCRIPTION	EBG COMMENTS
		The definition is based on DIRECTIVE 2009/72/EC OF THE EUROPEAN PARLIAMENT AND OF THE COUNCIL of 13 July 2009 concerning common rules for the internal market in electricity and repealing Directive 2003/54/EC, Article 2 (Definitions).	
Role	Trade Responsible Party	<p>A party who can be brought to rights, legally and financially, for any imbalance between energy nominated and consumed for all associated Accounting Points.</p> <p>Note:</p> <p>A power exchange without any privileged responsibilities acts as a Trade Responsible Party.</p> <p>Additional information:</p> <p>This is a type of Balance Responsible Party.</p>	Upstream role – second priority.
Role	Transmission Capacity Allocator	<p>The Transmission Capacity Allocator manages, on behalf of the System Operators, the allocation of available transmission capacity for a Bidding Zone Border. He offers the available transmission capacity to the market, allocates the available transmission capacity to individual Capacity Traders and calculates the billing amount of already allocated capacities to the Capacity Traders.</p> <p>Additional Information:</p> <p>The single allocation platform established by all TSOs for Forward Capacity Allocation performs the role of a Transmission Capacity Allocator.</p>	Upstream role – second priority.

A.2 Domains

DOMAINS			
Type	DOMAIN NAME	DESCRIPTION	EBG COMMENTS
Domain	Accounting Point	<p>A domain under balance responsibility where Energy Supplier change can take place and for which commercial business processes are defined.</p> <p>Additional information: This is a type of Metering Point.</p>	
Domain	Bidding Zone	<p>The largest geographical area within which market participants are able to exchange energy without capacity allocation.</p> <p>Source: Commission Regulation (EU) 543/2013.</p>	
Domain	Bidding Zone Border	<p>Defines the aggregated connection capacity between two Bidding Zones.</p> <p>A market area (Which defines the aggregated connection capacity between two Bidding Zones) where the transmission capacity between the Bidding Zones is given to the Balance Responsible Parties according to rules carried out by a Transmission Capacity Allocator. Trade between Bidding Zones is carried out on a bilateral or unilateral basis.</p>	
Domain	Capacity Calculation Region	<p>The Capacity Calculation Region is the geographic area in which coordinated capacity calculation is applied.</p> <p>Source: Commission Regulation (EU) 2015/1222 (CACM).</p> <p>Additional information: The transmission capacity between Bidding Zones, included in the Capacity Calculation Region, is given to the Balance Responsible Parties through an implicit capacity</p>	

DOMAINS			
Type	DOMAIN NAME	DESCRIPTION	EBG COMMENTS
		allocation process or through an explicit allocation auction.	
Domain	Control Area	<p>A coherent part of the interconnected system, operated by a single System Operator and shall include connected physical loads and/or generation units if any.</p> <p>Additional information: Source: Commission Regulation (EU) 543/2013.</p>	
Domain	Coordination Centre Zone	The composition of a number of LFC Blocks under the responsibility of the same Coordination Centre Operator.	
Domain	Exchange Point	<p>A domain for establishing energy exchange between two Metering Grid Areas.</p> <p>Additional information: This is a type of Metering Point.</p>	
Domain	FRR Sharing Region	<p>A set of LFC Areas of the same synchronous area, but not necessarily the same Bidding Zone. All LFC Areas of a FRR Sharing Region share a certain amount of FRR with each other.</p> <p>Additional information: Based on: System Operation Guideline, Commission Regulation (EU) 2017/1485, Article 168.</p>	
Domain	LFC Area	A part of a synchronous area or an entire synchronous area, physically demarcated by points of measurement at interconnectors to other LFC Areas, operated by one or more TSOs fulfilling the obligations of load-frequency control.	

DOMAINS			
Type	DOMAIN NAME	DESCRIPTION	EBG COMMENTS
		<p>Source: System Operation Guideline, Commission Regulation (EU) 2017/1485.</p>	
Domain	LFC Block	<p>A part of a synchronous area or an entire synchronous area, physically demarcated by points of measurement at interconnectors to other LFC Blocks, consisting of one or more LFC Areas, operated by one or more TSOs fulfilling the obligations of load-frequency control.</p> <p>Source: System Operation Guideline, Commission Regulation (EU) 2017/1485.</p>	
Domain	Metering Grid Area	<p>A Metering Grid Area is a physical area where consumption, production and exchange can be measured. It is delimited by the placement of meters for continuous measurement for input to, and withdrawal from the area.</p> <p>Additional information: It can be used to establish volumes that cannot be measured such as network losses.</p>	
Domain	Metering Point	An entity where energy products are measured or computed.	
Domain	RGCE Interconnected Group	The composition of a number of Coordination Centre Zones, operating under RGCE (Regional Group Continental Europe) rules, where the exchange and compensation programmes within the zone must sum up to zero.	
Domain	Scheduling Area	<p>An area within which the TSOs' obligations regarding scheduling apply due to operational or organisational needs.</p> <p>This area consists of one or more Metering Grid Areas with common</p>	<p>20221031:</p> <ul style="list-style-type: none"> Rephrase to: This area consists of one or more Metering Grid Areas with common market rules for which the settlement responsible party carries

Commented [GF4]: This needs proper definitions for consumption etc, I suggest they need to be linked to a grid, otherwise the grid needs to be in the definition

Commented [GF5]: grid

Commented [GF6]: I guess this needs linking to the grid for the energy product and why not energy flows to or from the grid

Commented [ON8]: Start here next meeting (November 21)

DOMAINS			
Type	DOMAIN NAME	DESCRIPTION	EBG COMMENTS
		<p>market rules for which the settlement responsible party carries out an imbalance settlement and which has the same price for imbalance.</p> <p>Source: System Operation Guideline, Commission Regulation (EU) 2017/1485.</p> <p>Additional information: This covers both Imbalance Area and Imbalance Price Area from the Electricity Balancing Guideline (2017/2195).</p>	<p>out an imbalance settlement and which has the same price for imbalance.</p> <p>Source: System Operation Guideline, Commission Regulation (EU) 2017/1485.</p> <p>Additional information: An area within which the TSOs' obligations regarding scheduling apply due to operational or organisational needs.</p> <p>This covers both Imbalance Area and Imbalance Price Area from the Electricity Balancing Guideline (2017/2195).</p>
Domain	Synchronous Area	<p>An area covered by synchronously interconnected LFC blocks.</p> <p>Note: Examples of Synchronous Areas are Continental Europe, Great Britain, Ireland-Northern Ireland, Nordic and the power systems of Lithuania, Latvia and Estonia, together referred to as 'Baltic' which are part of a wider synchronous area (IPS/UPS).</p> <p>Source: Requirements for Generators. Art. 2 - Definitions</p>	

Commented [GF9]: Proposal:
An area consisting of one or more MGA's (CVA's/...) that is under the legal obligation for scheduling

Where scheduling needs properly defined, containing at least the imbalance settlement

Commented [GF7]: These are not defined in the domainlist

Appendix B EBG project and survey list

B.1 Potential projects

#	Project description	Priority	Start
A)	Review what attributes to send in a confirmation (e.g. all from the request, only approve/disapprove or some core attributes, such as AP)	High	After finalising RtR
B)	Review and propose update to the HEMRM, based on new procedures from ETC and EBG, ref minutes from ebIX® Forum meeting March 24 th , 2020, including: <ul style="list-style-type: none"> Update definition of Accounting Point in the HRM based on the flex project. Make a preproposal for update of the definition of the «Harmonised Role» Resource Provider. Among others we think it is the BRP that sends schedules and not the Resource Provider and we think the term “manages” could be clarified. 	High	After finalising RtR
C)	Efficient data alignment, including the possibility to request historical and/or future master data. See “very general” data act from EU: https://ec.europa.eu/info/law/better-regulation/have-your-say/initiatives/13045-Data-Act-amended-rules-on-the-legal-protection-of-databases_en	Not prioritised	EBG must do a survey for the need of such a project
D)	Discuss differentiation of data sets per Entitled Role when aligning master data (e.g. when referencing notification of AP master data in a BRS) based on GDPR	High	After A) and B)
E)	Making a BRS for alignment of Exchange Point characteristics	High	Hopefully a part of the common energy market area project
F)	Making an introduction to the ebIX® BRSs, including an overview of the BRSs and a short description.	In finalising RtR	TBD
G)	Review of MR NMEG 2021/3 – Addition of a Reporting resolution and Reporting Interval to the AP Administrative Characteristics class. in Alignment of AP characteristics BRS	Medium	After finalising RtR
H)	It is assumed that the EC will decide to use IEC basic CIM as the reference Information Model, hence we should bring our definitions in line with IEC CIM. This can be done by changing our definitions, or by submitting maintenance requests to IEC TC57/wg16 (eventually to be forwarded by wg16 to wg14).	Medium	After A), B) and G)
I)	Update of Gas Role Model with addition of Aggregated Reception Station, Calorific Value Area and Temperature Area for gas.	Low	When the Gas Role Model starts adding domains.
J)	Investigate if services, such as flex-services should be added to BRS for Measure for billing. If so, we need to add a Resource ID to the class diagram(s) and extend the Basic assumption chapter.	This is a to-remember item	When the flex project is finalised

#	Project description	Priority	Start
K)	Verify extensions to the definitions of roles with the group harmonising the electricity and gas markets role models before adding the extension to the role definitions in a BRS to include gas.	Continuous	When updating role definitions in BRSs
L)	Review of BRS for Settle for Reconciliation, ref. minutes from EBG meeting October 10th, 2022.	Low	Autumn 2024

B.2 Approved (and running) projects

#	Project	Members	Status	Start	End
A)	RtR, Role-to-Role (hub)	All EBG	Start October 2018	Q4 2018	Q4 2021
B)	Common energy market area project	EBG: Bartosz, Boštjan (?), Gerrit, Kees and Ove. “External”: Douglas (ENTSOG), Jon-Egil (ENTSO-E/CIM EG) and ? from EU DSO Entity	Hopefully start October 2022	October 2022?	?

B.3 Surveys

#	Survey	Status
A)	Datahub	20220609: Third version sent to ebIX® members for update

Appendix C Mapping from ebIX® class diagrams for Validated measured data for continuous metered AP to CIM

The mapping will be reviewed by ETC, while EBG will look into the definitions of classes and attributes to see if we need to update the ebIX® definitions or if we should send maintenance requests to IEC for update of the CIM definitions.

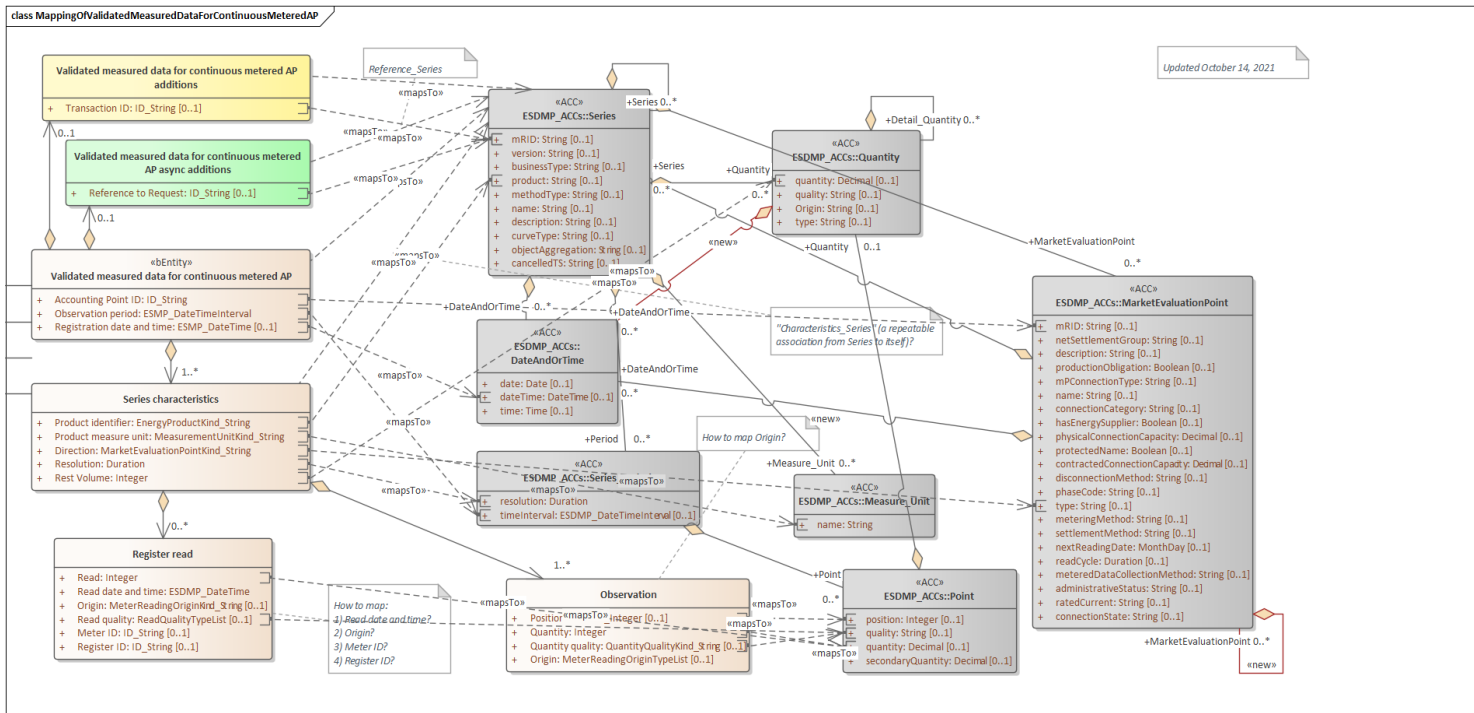

BRS attribute	BRS definition	CIM attribute	CIM definition
«Business entity» Validated measured data for continuous metered AP	The information set sent by a Metered Data Responsible to the Metered Data Administrator when exchanging validated measured data for continuous metered AP	Series	A set of similar physical or conceptual objects defined for the same period or point of time.
Accounting Point ID	The unique identification of the Accounting Point to which the validated measured data are attributed.	MarketEvaluationPoint / mRID	Master resource identifier issued by a model authority. The mRID is unique within an exchange context. Global uniqueness is easily achieved by using a UUID, as specified in RFC 4122, for the mRID. The use of UUID is strongly recommended. For CIMXML data files in RDF syntax conforming to IEC 61970-552, the mRID is mapped to rdf:ID or rdf:about attributes that identify CIM object elements.
Observation period	The specific period of time the validated measured data have been measured, calculated or estimated for.	Series_Period / timeInterval	The start and end date and time for a given interval.
Registration date and time	The date and time of the validation (and storage in the database) of this set of validated measured data.	DateAndOrTime / dateTime	Date and time as per ISO 8601 YYYY-MM-DDThh:mm:ss.sssZ.
Series characteristics	The characteristics of this set of validated measured data, i.e., the product and flow direction.	Series	A set of similar physical or conceptual objects defined for the same period or point of time.
Product identifier	A code specifying the energy product for the quantities in this set of validated measured data.	Series / product	The type of the product such as Power, energy, reactive power, transport capacity that is the subject of the time series.
Product measure unit	The unit of measure used for the quantities in this set of validated measured data.	Measure_Unit / name	The coded representation of the unit.
Direction	A code specifying the direction of the energy flow that was measured with this validated measured data. A flow from the Accounting Point into the Metering Grid Area is defined as production and a flow from the Metering Grid Area into the Accounting Point is defined as consumption.	MarketEvaluationPoint / type	Specifies if the Market Evaluation Point is an Exchange Point or an Accounting Point.

BRS attribute	BRS definition	CIM attribute	CIM definition
Resolution	<p>The resolution is the time between two observations, leading to the number of observations in this timeseries (calculated from the Observation Period divided by the Resolution).</p> <p>The Observation Period must contain a whole number of observations as derived from the resolution.</p> <p>The resolution is expressed in compliance with ISO 8601 in the following format:</p> <p style="text-align: center;">PnYnMnDnHnMnS.</p> <p>For example PT15M for 15 minutes resolution.</p>	Series / resolution	The number of units of time that compose an individual step within a period.
Rest Volume	The Rest Volume is used for a volume that cannot be related to the 'normal' measured time series observations, i.e., the difference, for the Observation Period, between the start-and end meter read and the aggregated volume from the exchanged time series.	Quantity / quantity	<p>The quantity value.</p> <p>The association role provides the information about what is expressed.</p>
Register read	A read from the register of the Meter linked to the Accounting Point and characteristics of the read. This read is at the basis of the validated measured data in the Observation.	N/A	
Read ³	The value as read from or calculated for the register, for this Read date and time in the Observation period.	Point / quantity	Principal quantity identified for a point.
Read date and time	The timestamp of the moment in time when the value was registered in the Register of the Meter or the value was calculated for.	N/A	
Origin	A code specifying the role of the party that has retrieved or calculated the read.	N/A	
Read quality	The quality of this read, such as estimated, remotely read or physically read.	Point / quality	The quality of the information being provided. This quality may be estimated, not available, as provided, etc.
Meter ID	The unique identification of the Meter linked to the Accounting Point, which contains the register that has been read.	N/A	

³ If the Register read is missing, the Meter Reading Origin Code shall be "E28 From Metered Data Responsible" and the Quantity Quality Code shall be "56 Estimated".

BRS attribute	BRS definition	CIM attribute	CIM definition
Register ID	The unique identification of the Register within the Meter, where this data has been read from or is estimated for.	N/A	
Observation	One validated measured value within a timeseries.	N/A	
Position	The ordinal position of this Observation in this Observation Period for this set of validated measured data.	Point / position	A sequential value representing the relative position within a given time interval.
Quantity	The validated quantity of energy for this Observation.	Point / quantity	Principal quantity identified for a point.
Quantity quality	The quality of this quantity (volume), such as validated (default value, hence not sent), estimated, or temporary.	Point / quality	The quality of the information being provided. This quality may be estimated, not available, as provided, etc.
Origin	A code specifying the role of the party delivering the Quantity.	N/A	
Validated measured data for continuous metered AP additions	Additional information, related to validated measured data, the use of which may be agreed on a national level.	Series	A set of similar physical or conceptual objects defined for the same period or point of time.
Transaction ID	The unique identification of this set of information as given by the Metered Data Responsible.	Series / mRID	Master resource identifier issued by a model authority. The mRID is unique within an exchange context. Global uniqueness is easily achieved by using a UUID, as specified in RFC 4122, for the mRID. The use of UUID is strongly recommended. For CIMXML data files in RDF syntax conforming to IEC 61970-552, the mRID is mapped to rdf:ID or rdf:about attributes that identify CIM object elements.
Validated measured data for continuous metered AP async additions	Additional information related to validated measured data needed when using asynchronous communication.	Series	A set of similar physical or conceptual objects defined for the same period or point of time.
Reference to request	Information about the request for this set of validated measured data for continuous metered AP which uniquely identifies it.	Series / mRID	Master resource identifier issued by a model authority. The mRID is unique within an exchange context. Global uniqueness is easily achieved by using a UUID, as specified in RFC 4122, for the mRID. The use of UUID is strongly recommended. For CIMXML data files in RDF syntax conforming to IEC 61970-552, the mRID is mapped to rdf:ID or rdf:about attributes that identify CIM object elements.

class MappingOfValidatedMeasuredDataForContinuousMeteredAP							
Target Source	1 DateAndOrTime	2 MarketEvaluationPoint	3 Measure_Unit	4 Point	5 Quantity	6 Series	7 Series_Period
1 Observation				Maps To Quant... → quantity Maps To Position → position Maps To Quantity → quantity			
2 Register read				Maps To Read → quantity Maps To Read ... → quantity			
3 Series characteristics		Maps To Direct... → type	Maps To Produ... → name		Maps To Rest V... → quantity	Maps To Produ... → product Maps To →	Maps To Resol... → resolu...
4 Validated measured dat...	Maps To Regist... → dateTi...	Maps To Accou... → mRID				Maps To →	Maps To Obser... → time...
5 Validated measured dat...						Maps To Trans... → mRID Maps To →	
6 Validated measured dat...						Maps To → Maps To Refer... → mRID	