

Minutes EBG meeting	 European forum for energy Business Information eXchange
April 13 th , 2021	EBG (ebIX® Business Group)

Date: Monday, April 12th, 2021
Time: 14:00 – 15:30
Place: GoToMeeting
Present: Bostjan, SODO
Gerrit, EDSN
Jan, Svenska kraftnät
Joachim, Westnetz
Kees, TenneT
Ove, Edisys
Appendix A: Status for BRS review
Appendix B: EBG project and survey list
Attachments: None

1 Approval of agenda

The agenda was approved with the following additions:

- Issues arising from ebIX® Forum meeting March 23rd, see item 7.1 under AOB;
- Review of BRS for Validated measured data, see item 7.2 under AOB;
- When to use Affected roles, Linked roles and Entitled roles? See item 7.4 under AOB;
- Metered data collection method, see item 7.5 under AOB;
- Is the centre of measure data linked to Metering Point (MP) or a Customer? see item 7.6 under AOB.

2 Approval of minutes from previous meeting

The meeting was used to discuss items under AOB; hence we never came to this item. Approval of the minutes will be put on the next meeting agenda.

3 Continue review BRS for Measure for Billing

Due to lack of time the item was postponed.

4 EU directive 2019/944 of June 5th, 2019 on common rules for the internal market for electricity

Due to lack of time the item was postponed.

5 MRs for the Harmonised Role Model

Due to lack of time the item was postponed.

6 Meeting schedule

Corona GoToMeetings:

- Every Monday from 14:00 to 15:30, now scheduled until end of July 5th, except for holydays.
- Wednesday May 19th from 10:00 to 11:30 replaces the meetings May 17th and May 24th that falls on holidays.

Normal scheduled face-to-face meetings:

- No face-to-face meeting planned. However, the next physical meeting is expected to be at:

PSE S.A.
Warszawska 165 street
05-520 Konstancin-Jeziorna
Poland

The link to the meeting ID in the invitation for this meeting and also for the rest of the meeting invitations until July 5th had for some unknown reason been corrupted, hence Ove had sent a new meeting invitation for this meeting.

Action:

- Ove will also replace the other invitations until July 5th with new invitations with a valid link.

7 AOB

7.1 Issues arising from ebIX® Forum meeting March 23rd

Review of EG1 Implementation Acts:

Since it looks like the next draft Implementation Act from EG1 will be more mature, it is important for ebIX® to comment on it. We should organise this with members from all ebIX® groups (ebIX® Forum, EBG, ETC). Kees expects the next round of commenting before (or during) summer this year.

Action 2021a-01:

- Ove will, together with EBG, invite ebIX® Forum, EBG and ETC (who may bring extra experts to the group) to a first planning and preparation meeting May 18th 10:00 - 11:30.

ebIX® and CIM EG Area project:

Leslaw from PSE informed at the latest HG meeting that CIM EG/ENTSO-E does not have enough resources to join this project now.

Decisions related to Area project:

- How to organise the Area project as a new project like the distributed flexibility project phase II (with participants from other European bodies) will be put on the ebIX® Forum autumn agenda. Earliest start is expected Q2 2022.

Action:

- Ove will send an invitation to EBG and ETC members not being members of ebIX® Forum.
- To prepare an agenda for the “review of EG1 Implementation Acts” will be put on EBG agenda for May 3rd.
- A review of the project plan for an ebIX® Area project will be put on an EBG/RtR agenda beginning of September.

Item closed.

7.2 Review of BRS for Validated measured data

Gerrit and Kees have done a review on the BRS for validated measured data that is up for final review (for 2 weeks) and had some issues that should be corrected. The first few comments were discussed and among others the following agreed:

- We remove most of the entries in chapter “A.3 Main changes since last version” – we keep one row.
- We agreed to replace Validator with Metered Data Responsible throughout the BRS.
- It was a longer discussion if the Installation should be replaced with Resource, or vice versa, but it was not reached any conclusion. However, it was started on a clarification of the content of a MP:

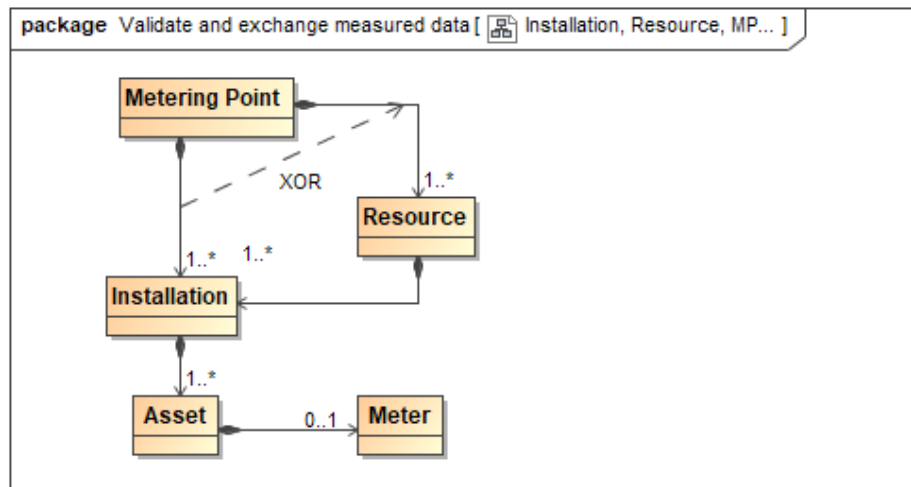

The discussion will be continued at the next meeting.

At the next meeting review should continue from chapter “1.2 Basic assumptions” (top of page 7).

7.3 Quantity Quality codes

We need a discussion on the Quantity Quality codes. The list in the ebIX® BRSs is OK, but there is a long list in the ebIX® code list.

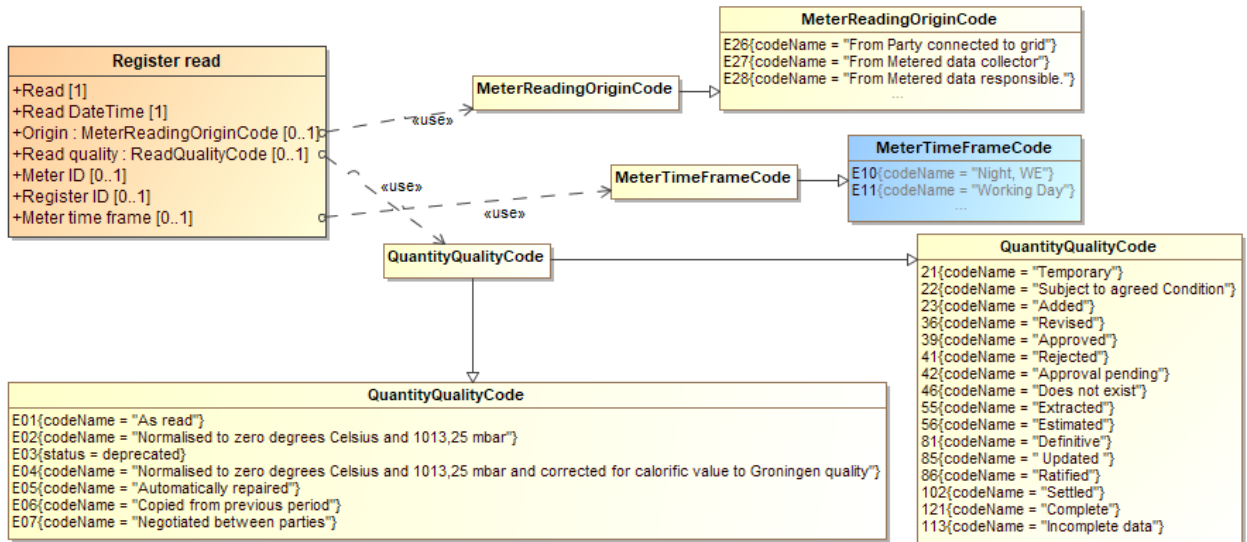

Due to lack of time the item was postponed.

7.4 When to use Affected roles, Linked roles and Entitled roles?

During the latest Flex project meeting it was noted that we should make some clear rules for when to use Affected role, Linked role or Entitled role. However, due to lack of time the item was postponed.

7.5 Metered data collection method

It was noted during the latest project meeting of the Distributed Flexibility project phase II that the “Metered data collection method” is part of both the “Accounting Point characteristics” and the “Metering configuration characteristics”.

Due to lack of time also this item was postponed.

7.6 Is the centre of measure data linked to Metering Point (MP) or a Customer?

Kees brought up the question, based on some discussions within EG1 – there the main view is that measure data is (primary) connected to a Customer and not a MP.

It was agreed that the Customer probably will be more important in the future as a starting point for processes, however the Customer will not replace the MP in the foreseeable future.

Conclusion:

- In the present, the MP is the centre point, but in the future the Customer may be the centre point.

Item closed.

Appendix A Status for BRS review

Structure BRSs			
#	BRS	Status	Comment
1.	Administer Customer Consent	Published at www.ebix.org	Finished
2.	Alignment of Accounting Point characteristics	Published at www.ebix.org	Finished To remember: Review of MR NMEG 2021/2 – Addition of a Supply Start Date to the AP Administrative Characteristics class, To remember: Review of MR NMEG 2021/3 – Addition of a Reporting resolution and Reporting Interval to the AP Administrative Characteristics class.
3.	Alignment of Area Characteristics	Published at www.ebix.org	
4.	Alignment of characteristics for a Customer linked to an AP	Published at www.ebix.org	Finished
5.	Alignment of Metering Configuration Characteristics	Published at www.ebix.org	Finished
6.	Bulk change of BRP	Published at www.ebix.org	Finished
7.	Bulk change of Shipper	Published at www.ebix.org	Finished
8.	Change of BRP	Published at www.ebix.org	Finished
9.	Change of Metered Data Responsible	Published at www.ebix.org	Finished
10.	Change of Shipper	Published at www.ebix.org	Finished
11.	Change of supplier	Published at www.ebix.org	Finished
12.	Combined grid and supply billing	Published at www.ebix.org	Finished
13.	Consented (earlier Upfront) request for Metering Point Characteristics	Published at www.ebix.org	Finished
14.	Customer move	Published at www.ebix.org	Finished
15.	End of Metered Data Responsible	Published at www.ebix.org	Finished
16.	End of supply	Published at www.ebix.org	Finished

Structure BRSs			
#	BRS	Status	Comment
17.	Manage Accounting Points	Published at www.ebix.org	Finished
18.	Rearrange MPs between grids	Published at www.ebix.org	Finished

Measure BRSs			
#	BRS	Status	Comment
1.	BRS for Measure Calorific Value	To be reviewed	20210125: <ul style="list-style-type: none"> Investigate the need for addition of MDR and MGA in the “root class”, ref Dutch requirements.
2.	BRS for Measure for Billing	20200831: <ul style="list-style-type: none"> TBD 	20210125: <ul style="list-style-type: none"> Investigate the need for addition of MDR and MGA in the “root class”, ref Dutch requirements.
3.	BRS Validated measured dat	20210315: <ul style="list-style-type: none"> Final review by EBG (14 days) before sent to ebIX® Forum for approval. 	
4.	BRS for Measure for Collected Data	20200402: <ul style="list-style-type: none"> Published at www.ebix.org. 	Finished. The BRS may be used as a template for how the Measure BRS may look like. 20200608: <ul style="list-style-type: none"> “Collected Data” should be renamed to “Collected <i>Measured</i> Data”
5.	BRS for Measure for Determine Meter Read	To be reviewed	20210125: <ul style="list-style-type: none"> Investigate the need for addition of MDR and MGA in the “root class”, ref Dutch requirements.

Measure BRSs			
#	BRS	Status	Comment
6.	BRS for Measure for Imbalance Settlement	To be reviewed	<p>20200615:</p> <ul style="list-style-type: none"> • Include handling of MR “NMEG 2020-01”. <p>20210125:</p> <ul style="list-style-type: none"> • Investigate the need for addition of MDR and MGA in the “root class”, ref Dutch requirements.
7.	BRS for Measure for Labeling	<ul style="list-style-type: none"> • Review started at GoToMeeting February 17th; 	<p>20210125:</p> <ul style="list-style-type: none"> • Investigate the need for addition of MDR and MGA in the “root class”, ref Dutch requirements.
8.	BRS for Measure for Reconciliation	To be reviewed	<p>20210125:</p> <ul style="list-style-type: none"> • Investigate the need for addition of MDR and MGA in the “root class”, ref Dutch requirements.
9.	BRS for Settle for Reconciliation	To be reviewed	<p>20210125:</p> <ul style="list-style-type: none"> • Investigate the need for addition of MDR and MGA in the “root class”, ref Dutch requirements.

Appendix B EBG project and survey list

B.1 Potential projects

#	Project description	Priority	Start
A)	Review what attributes to send in a confirmation (e.g. all from the request, only approve/disapprove or some core attributes, such as AP)	First possible face-to-face meeting	First possible face-to-face meeting
B)	Review and propose update to the HRM, based on new procedures from ETC and EBG, ref minutes from ebIX® Forum meeting March 24 th , 2020.	After review of BRSs	TBD
C)	Efficient data alignment, including the possibility to request historical and/or future master data.	EBG must do a survey for the need of such a project	Not prioritised
D)	Discuss differentiation of data sets per Entitled Role when aligning master data (e.g. when referencing notification of AP master data in a BRS)	EBG task – will be linked to “C), Efficient data alignment” task and GDPR	To be started Q1 2021
E)	Making a BRS for alignment of Exchange Point characteristics	TBD	TBD
F)	1) Making MRs to the HG for definition for and relations between Gateway, Gateway Operator and Gateway Administrator 2) Making a BRS for Gateway related stuff.	Awaiting decision in Germany or elsewhere	TBD
G)	Making an introduction to the ebIX® BRSs, including an overview of the BRSs and a short description.	In finalising RtR	TBD
H)	Review of MR NMEG 2021/2 (to ebIX®) – Addition of a Supply Start Date to the AP Administrative Characteristics class in Alignment of AP characteristics BRS	TBD	TBD
I)	Review of MR NMEG 2021/3 – Addition of a Reporting resolution and Reporting Interval to the AP Administrative Characteristics class. in Alignment of AP characteristics BRS	TBD	TBD

B.2 Approved (and running) projects

#	Project	EBG members	Status	Start	End
A)	RtR, Role-to-Role (hub)	All EBG	Start October 2018	Q4 2018	Q4 2021

B.3 Surveys

#	Survey	Status
A)		•